



The New Piper Aircraft, Inc.
2926 Piper Drive
Vero Beach, Florida, U.S.A. 32960

SERVICE No. 1041 BULLETIN

PIPER CONSIDERS COMPLIANCE MANDATORY

Date: September 25, 2000

(S/M)

SUBJECT:

**Distribution of Airborne Service Letter Number 56,
“Inspection and Cleaning of Airborne Air Filter Elements”**

MODELS AFFECTED:

SERIAL NUMBERS AFFECTED:

A guide to Models and Serial Numbers Affected is listed on pages 2 and 3. Because of the possibility of service spares installations, all models and serial numbers must be checked for applicability.

Note:

Many of the Piper models listed use the Airborne Air Filter Element, Part Number D9-18-1 (Piper Code 757-899). See the current Piper Parts Catalog for parts applications and locations of Airborne Air Filter Elements used on your particular Piper model.

COMPLIANCE TIME:

In accordance with the attached Airborne Service Letter Number 56.

Caution:

Failure to comply with Airborne Service Letter Number 56 may result in loose particles contaminating the gyro vacuum/pressure system. Left uncorrected, reliability of the gyro vacuum/pressure system may be compromised.

PURPOSE:

We have been notified by Parker Hannifin Corporation, Airborne Division, that the possibility exists where the airplane’s gyro vacuum/pressure system may become contaminated by loose particles originating from the air filter element. To remedy this condition, Airborne has issued Service Letter Number 56, “Inspection and Cleaning of Airborne Air Filter Elements,” which requires inspection and cleaning of the air filter elements and associated gyro vacuum/pressure system plumbing.

Left uncorrected, reliability of the gyro vacuum/pressure system may be compromised.

APPROVAL:

The technical contents of this Service Bulletin have been approved by the FAA.

INSTRUCTIONS:

1. Refer to the attached Airborne Service Letter Number 56, “Inspection and Cleaning of Airborne Air Filter Elements,” and follow the instructions listed under Recommendation.

Note:

If there is evidence of loose particles in the air filter element, the possibility exists that particles may have entered the gyro vacuum/pressure system, and therefore the entire gyro vacuum/pressure system and components may require inspection.

2. Upon successful completion of Airborne Service Letter Number 56, make an appropriate logbook entry of compliance with this Service Bulletin.

(OVER)
ATA: 3714

Effectivity Reference Guide

MODELS AFFECTED:**SERIAL NUMBERS AFFECTED:**

PA-18/18A/18S (Super Cub)	18-1 through 18-9004, 18-7309016 through 18-8309025 1809001 through 1809113
PA-20/20S (Pacer)	20-1 through 20-1121
PA-22/22S (Tripacer/Caribbean/Colt)	22-1 through 22-9848
PA-23/23-160 (Apache)	23-1 through 23-2046
PA-23 235 (Apache)	27-505 through 27-622
PA-23-250/E23-250 (Aztec)	27-1 through 27-4866, 27-7304917 through 27-8154030
PA-24-180/250 (Comanche)	24-1 through 24-3687
PA-24-260 (Comanche)	24-3642, 24-4000 through 24-5028
PA-24-400 (Comanche)	26-2 through 26-148
PA-28-140 (Cherokee)	28-20000 through 28-7725290
PA-28-150/160/180/28S-160/180 (Cherokee)	28-1 through 28-7505259 & 28-E13
PA-28-151 (Warrior)	28-7415001 through 28-7715314
PA-28-161 (Warrior II)	28-7716002 through 28-8616057, 2816001 through 2816109
PA-28-161 (Warrior III)	2816110 through 2816119, 2842001 through 2842083
PA-28-161 (Cadet)	2841001 through 2841365
PA-28-181 (Archer II)	28-7690001 through 28-8690056, 2890001 through 2890205
PA-28-181 (Archer III)	2890206 through 2890231, 2843001 through 2843346
PA-28-235 (Cherokee)	28-10001 through 28-7710089 & 28-E11
PA-28-201T (Turbo Dakota)	28-7921001 through 28-7921091
PA-28-236 (Dakota)	28-7911001 through 28-8611008, 2811001 through 2811050
PA-28R-180 (Arrow)	28R-30001 through 28R-7130013
PA-28R-200 (Arrow/Arrow II)	28R-35001 through 28R-7635545
PA-28R-201 (Arrow III)	28R-7737002 through 28R-7837317
PA-28R-201 (Arrow)	2837001 through 2837061, 2844001 through 2844031
PA-28R-201T (Turbo Arrow III)	28R-7703002 through 28R-7803372, 2803001 through 2803015
PA-28RT-201 (Arrow IV)	28R-7918001 through 28R-8218026
PA-28RT-201T (Turbo Arrow IV)	28R-7931002 through 28R-8631005, 2831001 through 2131038
PA-30 (Twin Comanche)	30-1 through 30-2000
PA-31/300/325 (Navajo/Navajo CR)	31-2 through 31-861, 31-7300901 through 31-8312019
PA-31-350 (Chieftain)	31-5001 through 31-5004, 31-7305005 through 31-8452021
PA-31-350 (T1020)	31-8253001 through 31-8553002
PA-31P (Pressurized Navajo)	31P-3 through 31P-80, 31P-7300110 through 31P-7400230, 31P-7530001 through 31P-7730012
PA-31P-350 (Mojave)	31P-8414001 through 31P-8414050
PA-31T (Cheyenne/Cheyenne II)	31T-7400002 through 31T-7400009, 31T-7520001 through 31T-8120104

Effectivity Reference Guide (Cont'd)

MODELS AFFECTED:**SERIAL NUMBERS AFFECTED:**

PA-31T1 (Cheyenne I/IA)	31T-7804001 through 31T-8104101
	31T-8304001 through 31T-8304003,
	31T-1104004 through 31T-1104017
PA-31T2 (Cheyenne IIXL)	31T-8166001 through 31T-8166076,
	31T-1166001 through 31T-1166008
PA-31T3 (T1040)	31T-8275001 through 31T-8475001,
	31T-5575001
PA-32-260 (Cherokee Six)	32-1 through 32-7800008
PA-32-300/32S-300 (Cherokee Six)	32-40000 through 32-7940290
PA-32-301 (Saratoga)	32-8006001 through 32-8606023,
	3206001 through 3206019
PA-32-301T (Turbo Saratoga)	32-8024001 through 32-8424002
PA-32RT-300T (Turbo Lance II)	32R-7787001 through 32R-7987126
PA-32R-300 (Lance)	32R-7680001 through 32R-7880068
PA-32RT-300 (Lance II)	32R-7885001 through 32R-7985105
PA-32R-301 (Saratoga SP)	32R-8013001 through 32R-8613006,
	3213001 through 3213041
PA-32R-301 (Saratoga II HP)	3213029, 3213042 through 3213103,
	3246001 through 3246160
PA-32R-301T (Turbo Saratoga SP)	32R-8029001 through 32R-8629006,
	3229001 through 3229003
PA-32R-301T (Saratoga II TC)	3257001 through 3257145
PA-34-200 (Seneca)	34-7250001 through 34-7450220
PA-34-200T (Seneca II)	34-7570001 through 34-8170092
PA-34-220T (Seneca III)	34-8133001 through 34-8633031,
	3433001 through 3433216,
	3448001 through 3448035
PA-34-220T (Seneca IV)	3448038 through 3448079,
	3447001 through 3447029
PA-34-220T (Seneca V)	3449001 through 3449168
PA-36-285 (Pawnee Brave)	36-7360001 through 36-7660135,
PA-36-300 (Pawnee Brave)	36-7760001 through 36-8160023
PA-36-375 (Pawnee Brave)	36-7802001 through 36-8302025
PA-38-112 (Tomahawk)	38-78A0002 through 38-82A0124
PA-39 (Twin Comanche)	39-1 through 39-155
PA-40 (Arapaho)	40-7400002
PA-42/42-720 (Cheyenne III/IIIA)	42-7800001 through 42-7800002,
	42-7801003 through 42-8301002,
	42-5501003 through 42-5501060
PA-42-1000 (Cheyenne 400LS)	42-5527001 through 42-5527044
PA-44-180 (Seminole)	44-7995001 through 44-8195026,
	4495001 through 4495013,
	4496001 through 4496036
PA-44-180T (Seminole)	44-8107001 through 44-8207020
PA-46-310P (Malibu)	46-8408002 through 46-8608088,
	4608001 through 4608140
PA-46-350P (Malibu Mirage)	4622001 through 4622200,
	4636001 through 4636284

MATERIAL REQUIRED: N/A

AVAILABILITY OF PARTS: N/A

EFFECTIVE DATE: This Service Bulletin is effective upon receipt.

SUMMARY: Applicable Factory Participation is limited to new aircraft in warranty at the time of compliance. Factory Participation will remain in effect for a period of time **not to exceed 180 days** from the date of this Service Bulletin.

Please contact your Factory Authorized Piper Service Facility to make arrangements for compliance with this Service Bulletin in accordance with the compliance time indicated.

Please contact your Factory Authorized Piper Service Facility to make arrangements for compliance with this Service Bulletin in accordance with the compliance time indicated.

NOTE: If you are no longer in possession of this aircraft, please forward this information to the present owner/operator and notify the factory of address/ownership corrections. Changes should include aircraft model, serial number, current owner's name and address.

Corrections/changes should be directed to:

THE NEW PIPER AIRCRAFT, INC.
Attn: Customer Services
2926 Piper Drive
Vero Beach, FL 32960

Service Letter Number: 56

Date: 4/19/00

Subject: Inspection and Cleaning of Airborne Air Filter Elements.

Applicability: Airborne Air Filter Elements with the following part numbers/date codes which have not been inspected per this service letter as identified in step number seven (7) of the procedure listed below. These components were shipped from Airborne between 1/1/99 and 3/31/00.

<u>Item</u>	<u>Part Number (P/N)</u>	<u>Date Code</u>
Air Filter Element	D9-14-3 (See Note 1)	1AR thru 12AR and 1AT thru 3AT
Air Filter Element	D9-14-5 (See Note 2)	1AR thru 12AR and 1AT thru 3AT
Air Filter Element	D9-18-1 (See Note 3)	1AR thru 12AR and 1AT thru 3AT

Note 1: The D9-14-3 is used in the 1J2-2 Air Filter Assembly.

Note 2: The D9-14-5 is used in the 1J2-1, 1J2-5 and 1J2-6 Air Filter Assemblies.

Note 3: The D9-18-1 is used in the 1J7-1 and 1J7-2 Air Filter Assemblies.

Background: Field reports indicate the possibility that loose particles of a black elastomeric compound may not have been completely removed from these air filter elements during the manufacturing process.

Recommendation:

Within the next thirty days, inspect/clean the air filter elements listed above and also the associated pneumatic system plumbing per the following procedure:

- 1) Remove the affected air filter element from aircraft per the instructions outlined in the appropriate maintenance/service manual provided by the airframe manufacturer.
- 2) Inspect the inner diameter of the black end piece(s) of these elements for flashing (Figure 1). Remove all flashing using a sharp knife. Caution: Do not cut the paper filter portion of the element.

Airborne

Air & Fuel Products

Service Letter Number: 56 (Continued)

- 3) Tap the element lightly on a clean work surface in order to remove any loose particles from between the pleat tips on the inside of the paper filter (Figure 2).
- 4) Inspect the inner diameter (pleat tips) of the paper filter for black residue (Figure 3). Remove all loose residue using the "sticky side" of a strip of masking tape attached to the end of a blunt instrument.
- 5) Seal one end of the element using a plug. Then, use a heavy-duty vacuum cleaner (e.g. shop vac) to remove all loose particles from inside the element.
- 6) Thoroughly inspect all internal surfaces of the element for any loose particles. Remove any remaining loose particles using any combination of the above steps. Note: The wicking of black potting material onto pleats of paper filter is acceptable (Figure 4).
- 7) Identify the element as having been inspected per this service letter by permanently marking (ink stamp, magic marker, etc.) the number of this service letter ("56") on an exterior surface of the element. Note: This marking should be clearly visible once the element is installed back into the aircraft.
- 8) Remove the applicable pneumatic system hoses/lines as outlined below:
 - Vacuum System: Hoses/lines between system inlet filter and gyro instruments.
 - Pressure System: Hoses/lines between system inlet filter and dry air pump.
- 9) Clean hoses/lines using a heavy-duty vacuum cleaner (e.g. shop vac) and then reinstall.
- 10) Reinstall the clean air filter element per the instructions outlined in the appropriate maintenance/service manual provided by the airframe manufacturer.
- 11) Perform an operational check of the complete pneumatic system per the instructions outlined in the appropriate maintenance/service manual provided by the airframe manufacturer.
- 12) Any questions regarding this service letter should be directed to Airborne's Customer Support Team as follows:

<u>Toll Free Phone Number:</u>	800-382-8422
<u>Direct Phone Number:</u>	440-937-1315
<u>Fax Number:</u>	440-937-5409
<u>E-Mail:</u>	techhelp@parker.com

(Page 2 of 4)



Airborne

Air & Fuel Products

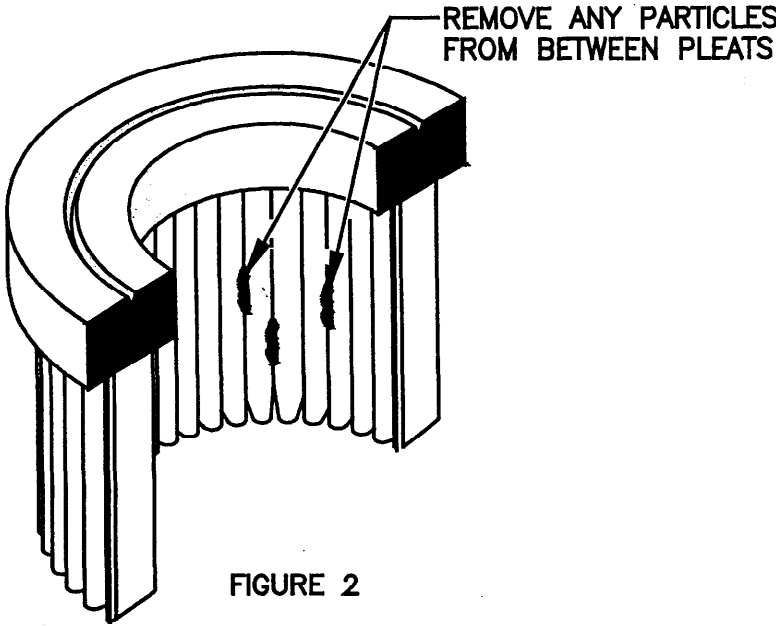
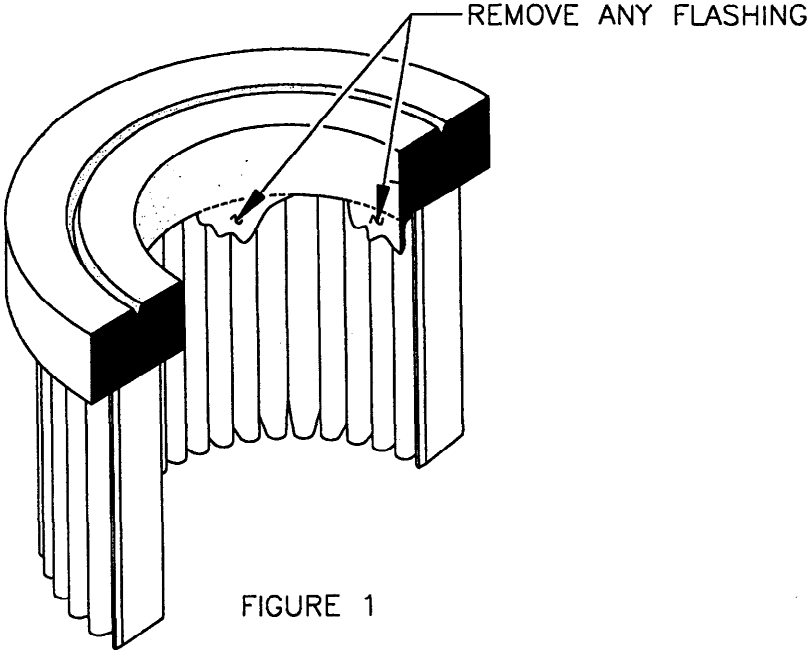

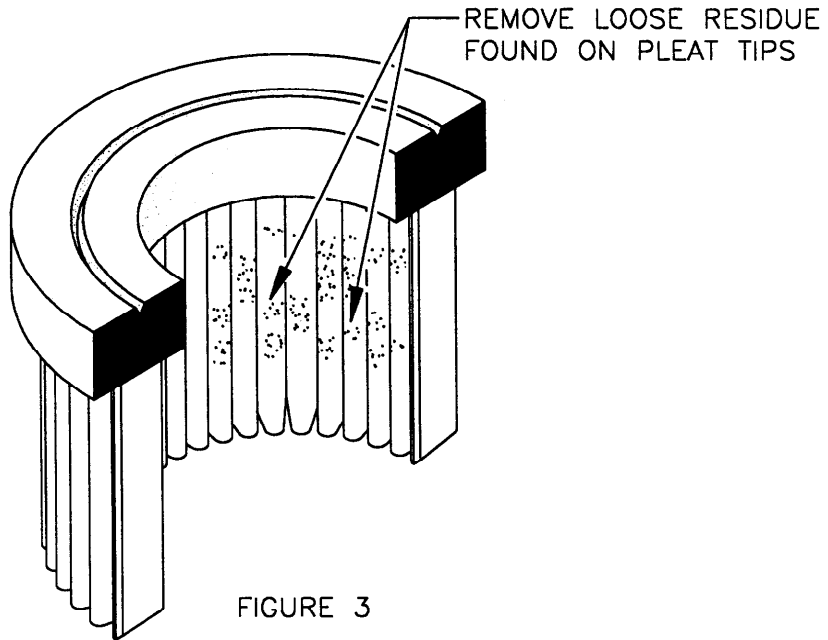

FIGURE 3

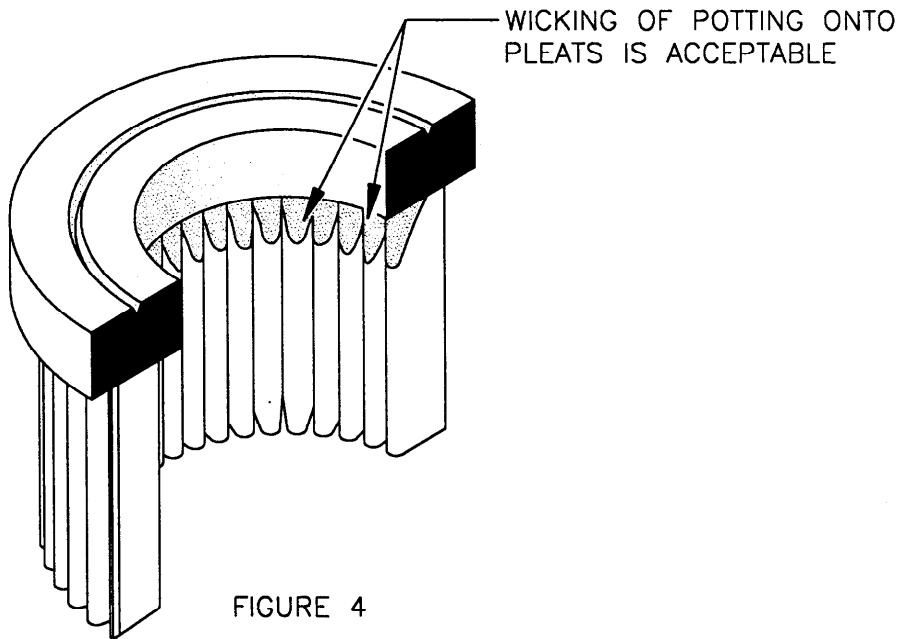

FIGURE 4